

Mobile inspection station LPS100 PM (5ft. & 2ft.)

BRILLIANT AND ENERGY EFFICIENT AT ANY LOCATION

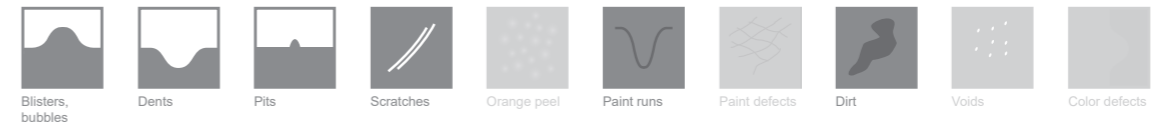

Mobile inspection station



The mobile inspection station is a location-independent solution that has been specially developed for flexible surface inspection. The sturdy aluminum frame carries two permanently mounted lights: a 5ft. light in vertical position for large area inspections and a 2ft. light at a 45° angle for detailed inspections in upper areas.

The mobile light unit is particularly suitable for the automotive sector: topcoat, assembly and audit sites



Features

- Assembly** Mobile light unit with:
- LPS100 PM 3 x 22 W
 - LPS100 PM 3 x 8 W
 - 2 x 6,500 K, 1 x 4,000 K
- LED controller**
- Electronic, dimmable, over push button
- Frame**
- Aluminum system profiles
 - Dimensions 90 x 45 mm
- Equipment**
- Storage for chemicals and accessories
 - Touch dimmer
 - 2 x hooks for tools
 - Double socket
 - 2 x handles
- Cable gland** Safety plug with 5 m connection cable

Technical specifications

- Permitted ambient temperature +5°C to +35°C
- Rated voltage 220-240 V, 50/60 Hz
- Degree of protection IP54
- Protection class I
- UGR limit ≤19

Quality criteria

- Photobiological safety (EN 62471): Risk group 0
- CE label

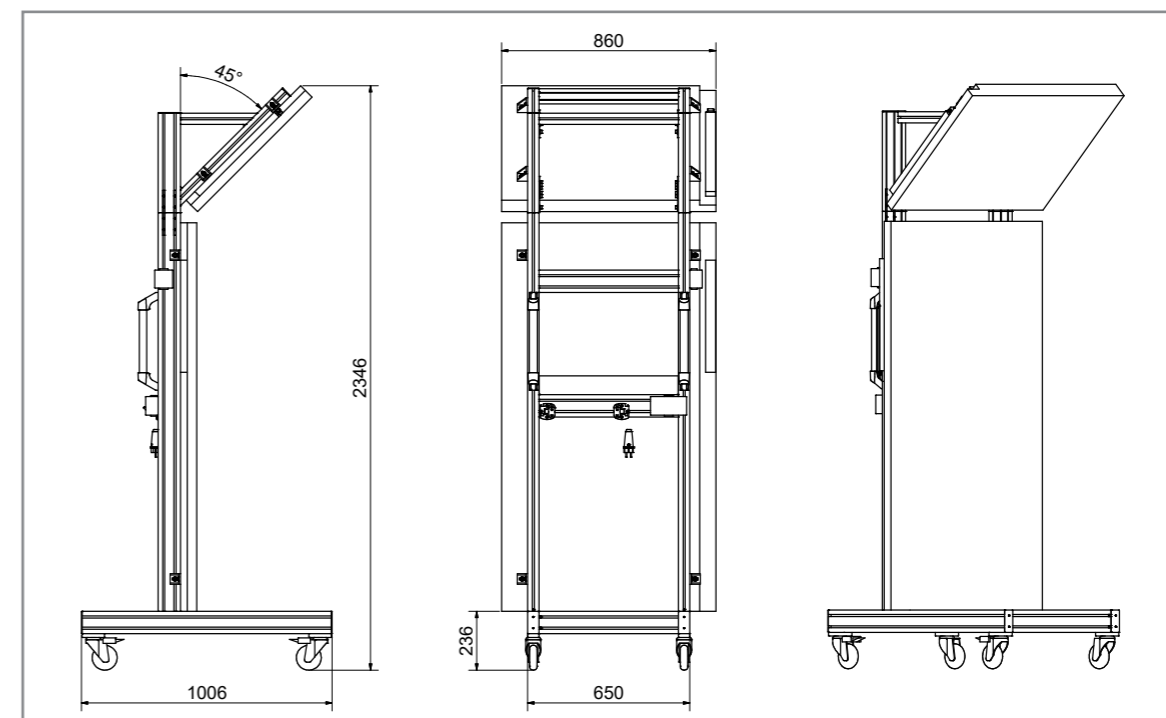

Exterior dimensions of the mobile inspection station LPS100 PM (5ft. & 2ft.). All dimensions in mm.

Order number	Type code	Lamps	Dimensions in mm (WxHxD)	Weight in kg
95400061	-	L701LD301 & L701LD305	860 x 2346 x 1006	approx. 111

- Subject to changes -

